

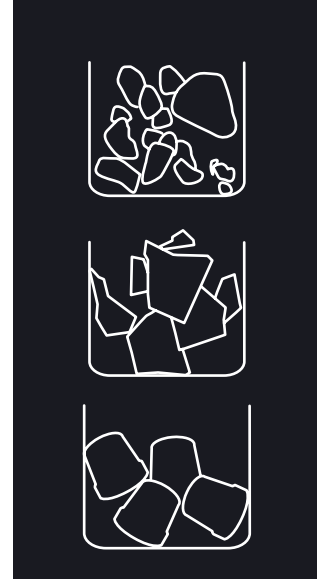

















SILO S350

ICE BIN FOR MODULAR ICE MACHINES FEATURES

- ▶ ICE BIN CAPACITY OF 340 KG
- ▶ AISI 304 STAINLESS STEEL BINS
- ▶ VERY HARD SANITARY POLYETHYLENE VAT, RESISTANT TO BLOWS, AND SCRATCHES
- ▶ EASY CLEANING DESIGN®: SEAMLESS ONE-PIECE VAT WITH ROUNDED CORNERS, AVOIDING POSSIBLE DIRTY POINTS AND FACILITATING CLEANING
- ▶ DRAINAGE SYSTEM THAT COLLECTS AND DRIVES THE WATER TO THE DRAIN KEEPING THE BIN CLEAN & DRY



ACCESSORIES

	MDP150/MR400/MP	SPIKA	QUASAR	ICE QUEEN	SCALA
 RECOMMENDED	 2 MDP150	<div style="border: 1px dashed black; padding: 2px; display: inline-block;">2</div>  1/2 MS220  MS300 SLIM <div style="border: 1px dashed black; padding: 2px; display: inline-block;">2</div>  1/2 MS410	 MQ200	<div style="border: 1px dashed black; padding: 2px; display: inline-block;">2</div>  2 IQ150  1/2 IQ200  IQ400  IQ550 <div style="border: 1px dashed black; padding: 2px; display: inline-block;">2</div>  1/2 IQ550 SPLIT <div style="border: 1px dashed black; padding: 2px; display: inline-block;">2</div>  1/2 IQ850 CO2 SPLIT  IQ1100 SPLIT	
 POSSIBLE (NOT OPTIMIZED)	 MDP150  MP145			 IQ150	 SCALA 400 SCALA 400 SPLIT

TECHNICAL SCHEME

SILO S350

RIGHT SIDE VIEW

FRONTAL VIEW

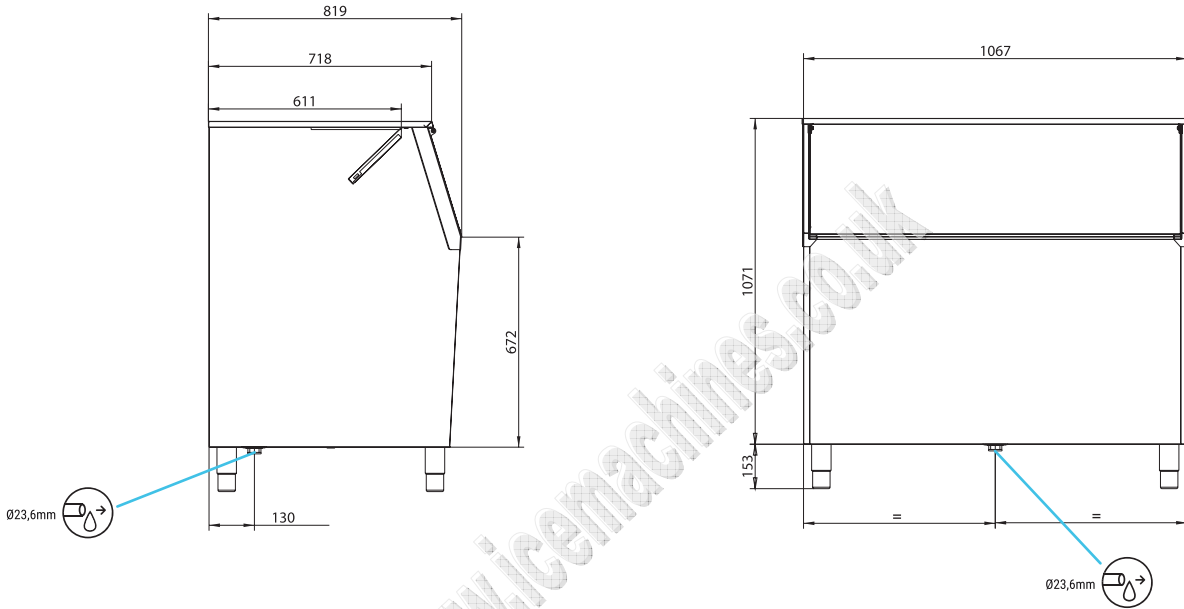

* All measurements in mm.

ACCESSORIES

INCLUDED



4 HEIGHT ADJUSTABLE LEG KIT



LARGE SCOOP



WATER OUTLET HOSE



DRAINAGE ELBOW



(Kg)



(Kg)



(mm)



(Kg)



(mm)



(Kg)

(m³)

SILO S350

340

272

Width 1.067
Depth 819
Height 1.071

69

Width 1.150
Depth 890
Height 1.210

90

1,24

*1.224 mm with legs