

SILO S400

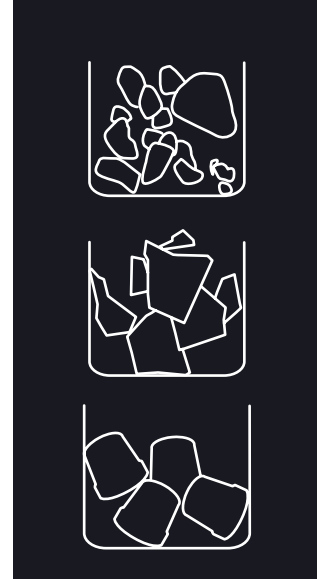









ICE BIN FOR MODULAR ICE MACHINES

FEATURES

- ▶ ICE BIN CAPACITY OF 390 KG
- ▶ AISI 304 STAINLESS STEEL BINS
- ▶ VERY HARD SANITARY POLYETHYLENE VAT, RESISTANT TO BLOWS, AND SCRATCHES
- ▶ EASY CLEANING DESIGN®: SEAMLESS ONE-PIECE VAT WITH ROUNDED CORNERS, AVOIDING POSSIBLE DIRTY POINTS AND FACILITATING CLEANING
- ▶ DRAINAGE SYSTEM THAT COLLECTS AND DRIVES THE WATER TO THE DRAIN KEEPING THE BIN CLEAN & DRY



RECOMMENDED MACHINES

	MDP150/MR400/MP	SPIKA	QUASAR	ICE QUEEN	SCALA
  RECOMMENDED	 2 MDP150	 1½ MS220		 2 IQ150 2 IQ200	 SCALA 400 SCALA 400 SPLIT
		 MS300 SLIM		 IQ400 IQ550	 1½ IQ550 SPLIT
		 1½ MS410		 1½ IQ850 CO2 SPLIT IQ1100 SPLIT	

  POSSIBLE (NOT OPTIMIZED) 15%	 MDP150	 MQ200	 IQ150
	 MP145		 IQ200
	 MR400		

TECHNICAL SCHEME ESQUEMA TÉCNICO

SILO S400

RIGHT SIDE VIEW

FRONTAL VIEW

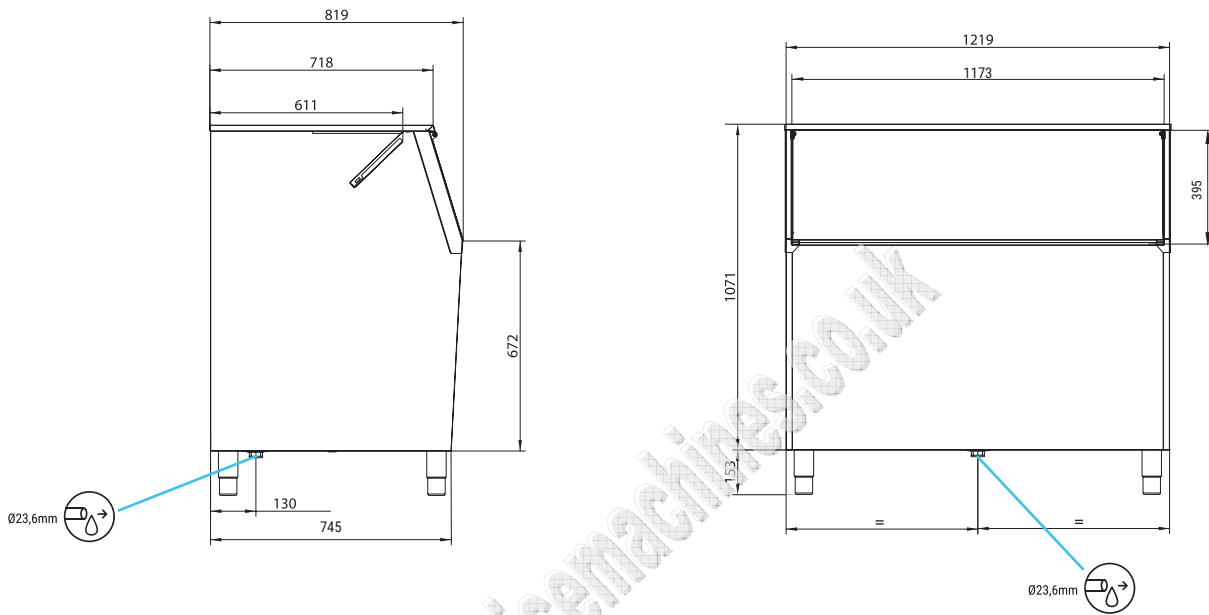

* All measurements in mm.

ACCESSORIES

INCLUDED



4 HEIGHT ADJUSTABLE LEG KIT



LARGE SCOOP



WATER OUTLET HOSE



DRAINAGE ELBOW



SILO S400

390

312

Width 1.219
Depth 819
Height 1.071

75

Width 1.300
Depth 890
Height 1.210

97

1,40

*1.224 mm with legs