

ICE QUEEN N 300 230 V / 50 Hz

MODULAR NUGGET ICE MACHINE

FEATURES

- ▶ PRODUCES NUGGET ICE
- ▶ HIGH EVAPORATOR EFFICIENCY: LOWER ENERGY CONSUMPTION AND HIGHER ICE PRODUCTION
- ▶ AUTODIAGNOSIS LED LIGHTS SIGNALING OPERATION STATUS & ALERTS
- ▶ ELECTRONIC CONTROL. ON/OFF LIGHTED SWITCH IN FRONT PANEL
- ▶ STAINLESS STEEL AUGER WITH RESILIENT COATING TO MAXIMIZE LIFESPAN
- ▶ POWERFUL MOTOR GEAR
- ▶ AISI 304 STAINLESS STEEL BODY
- ▶ OPTICAL PINPOINT CONTROL SYSTEM TO SET ICE STOCK LEVEL. ICE FALLS OUT THROUGH THE OPENING ON THE BOTTOM OF THE UNIT
- ▶ TROPICALIZED MACHINES (T CLASS)
- ▶ NATURAL GAS R290 WITH VERY LOW GLOBAL WARMING POTENTIAL WHICH ALSO REDUCES THE ENERGY CONSUMPTION

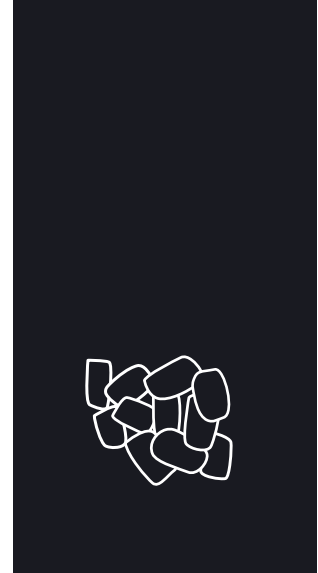

- EASI Easy Access for Service & Installation
- STIF Strong Inox Frame
- FRONT VENTILATION

! THE INSTALLATION OF AN ANTI-SCALE FILTER AND PERIODIC CLEANING ARE ADVISED IN AREAS WITH MEDIUM OR HIGH LIMESCALE CONTENT (HARD WATER)

	24 H	10°C	10°C	21°C	15°C			
	(Kg)	(Kg)	(Kg)	(Kg)	(Kg)	(mm)	(mm)	NUGGET ICE 90% DRY (+/-2%)
IQ N 300 A		378	378	378	378	Width 559 Depth 622 Height 712	Width 636 Depth 695 Height 835	
IQ N 300 W		-	-	-	-			

ACCESSORIES

INCLUDED	NOT INCLUDED (OPTIONAL)
WATER INLET FILTER GASKET WATER INLET HOSE WATER OUTLET HOSE	LARGE SCOOP ICE DELIVERY CHUTE DISPERSION CONE ANTI-LIMESCALE FILTER PARTICLE FILTER EXTERNAL STOP FULL BIN PHOTO CELL

RECOMMENDED BINS



TECHNICAL SCHEME

ICE QUEEN N 300



RIGHT SIDE VIEW

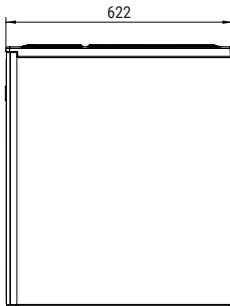

FRONTAL VIEW

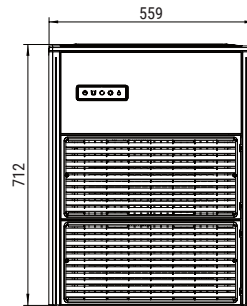

REAR VIEW

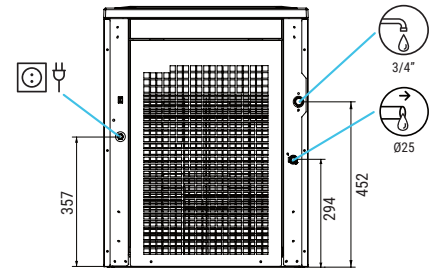

CENTRAL CROSS SECTION VIEW OF THE BASE

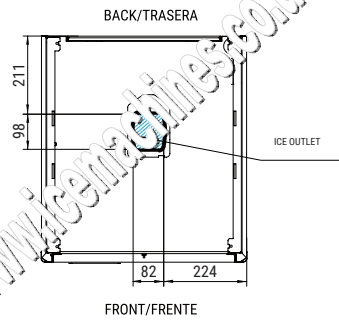

* All measurements in mm.

OPERATING CONDITIONS

PRODUCTION 50Hz

±10% V

10°C/43°C

5°C/38°C

1 bar/6 bar

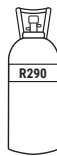

V	Hz	ph
230	50	1N

IQ N 300 AIR COOLED

	ASHRAE CONDITIONS			
	10° 50°	15° 60°	21° 70°	30° 86°
10° 50°	378	370	360	350
21° 68°	368	330	327	320
32° 90°	325	310	304	298
43° 109°	285	270	261	255

24 H

IQ N 300 WATER COOLED

	ASHRAE CONDITIONS			
	10° 50°	15° 60°	21° 70°	30° 86°
10° 50°	-	-	-	-
21° 68°	-	-	-	-
32° 90°	-	-	-	-
43° 109°	-	-	-	-

MODELS
MODELOS

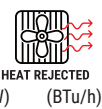

IQ N 300 A



3.240 11.055

1.316

3

1,5

16

7,9

15,2

2.544 8.680

84

93

0,37

IQ N 300 W



- -

-

-

-

-

-

-

- -

-

-

-



ITV ICE MAKERS, S.L.



SERVICE



Subject to certain limitations and exclusions. Only spare parts.



9001
14001

