



S-Series 322 Ice Cube Machine

Model

- SD-0322A
 SD-0323W
 SY-0324A
 SY-0325W



SD-0322A
Ice Machine on B-320 Bin

Standard Features

- Up to 340 lbs. (154 kgs.) daily ice production.
- CEE Tier 2 energy and water efficiency rating.
- Only 22" (55.88 cm) wide.
- Removable water distribution tube with no tools.
- Food zone designed with soft, round, cove corners.
- Patented cleaning and sanitizing technology.
- Select components made with AlphaSan® antimicrobial.
- Hinged front door for easy access.

Warranty

- 5-year parts and 5-year labor coverage on ice machine evaporator.
- 5-year parts and 3-year labor coverage on ice machine compressor.
- 3-year parts-and-labor coverage on all other ice machine, dispenser, and storage bin components.

Specifications

BTU Per Hour:

3,800 (average) 6,000 (peak)

Compressor:

Nominal rating: 1/2 HP

Cupra-Nickel Condenser:

(Water-cooled models)
Adds protection from corrosive water elements

Operating Limits:

- Ambient Temperature Range:
Air and water-cooled:
35° to 110°F (1.6° to 43.3°C)
- Water Temperature Range:
35° to 90°F (1.6° to 32.2°C)
- Water Pressure Ice Maker
Water In:
Min. 20 psi (137.9 kPa)
Max. 80 psi (551.1 kPa)
- Condenser Inlet Water In:
(Water cooled only)
Min. 20 psi (137.9 kPa)
Max. 150 psi (1,034.2 kPa)

Ice Machine Electric

115/60/1 standard. (208-230/60/1 and 230/50/1 also available.)

Minimum circuit ampacity:

Air-cooled: 11.3 amps
Water-cooled: 10.5 amps

Maximum fuse size:

Air-cooled and Water-cooled: 15 amps
HACR-type circuit breakers can be used in place of fuses.

Ice Shape



Half Dice
3/8" x 1 1/8" x 7/8"
(.95 x 2.86 x 2.22 cm)



Dice
7/8" x 7/8" x 7/8"
(2.22 x 2.22 x 2.22 cm)





S-Series 322 Ice Cube Machine

S-322 on B-320 Storage Bin

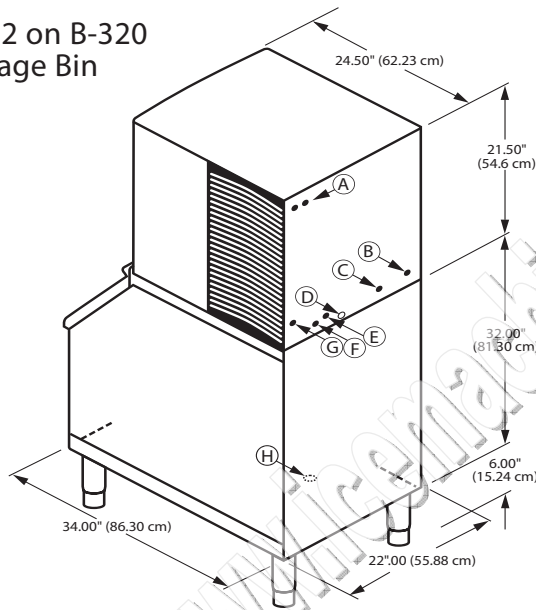

- (A) Electrical Entrance (2) Options
- (B) 3/8" (0.95 cm) F.P.T. Water Condenser Inlet (water-cooled units)
- (C) 1/2" (1.27 cm) F.P.T. Water Condenser Outlet (water-cooled units)
- (D) 1/2" (1.27 cm) Auxillary Base Drain Socket
- (E) 3/8" (0.95 cm) F.P.T. Ice Making Water Inlet
- (F) 1/2" (1.27 cm) F.P.T. Ice Making Water Drain
- (G) AuCS® Accessory Knockout
- (H) 3/4" (1.91 cm) Bin Drain

Installation Note
Minimum installation clearance: Top/sides: 8" (20.32 cm); Back: is 5" (12.7 cm).

Space-Saving Designs



	S-322 B-320	S-322 B-420
Height	59.50" 151.13 cm	71.50" 194.31 cm
Width	22.00" 55.88 cm	22.00" 55.88 cm
Depth	34.00" 86.30 cm	34.00" 86.30 cm
Bin Storage	210 lbs. 95 kgs.	310 lbs. 141 kgs.

Height includes adjustable bin legs 6.00" to 7.00", (15.24 to 17.78 cm) set at 6.00" (15.24 cm).
For comparison purposes multiply ARI capacity by 1.3 (30%) to arrive at approximate "Application Rating Capacity."

Model	Ice Shape	Ice Production 24 Hours				Power kWh/100 lbs. @ 90°/70°F	CEE† Rating	ENERGY STAR®
		70°Air/50°F Water		90°Air/70°F Water				
		lbs.	kgs.	lbs.	kgs.			
SD-0322A	dice	340	154	270	113	6.9	Tier 2	★
SD-0323W	dice	330	150	290	132	5.4	Tier 2	
SY-0324A	half-dice	340	154	270	113	6.9	Tier 2	★
SY-0325W	half-dice	330	150	290	132	5.4	Tier 2	
Water usage/100 lbs./45.4 kgs. of Ice								
Potable Water: 18 gallons, 68 liters • Water-cooled Condenser: 160 gallons, 605.6 liters.								

Order ice storage bin separately. "A" or "W" following model number indicates "Air" or "Water" condensing unit.

Air Flow Top View

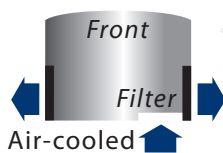

AuCS®SO Accessory

Automatic Cleaning System purchased as an option and installed in the field.